

## Connectors

The Model 210 connector locations are shown on Figure 1 and described below.

### Power Input

#### AC Power

The Model 210 is designed to be powered from the center-tapped secondary of a transformer as shown in Figure 2. The maximum recommended transformer secondary voltage is 48 VAC center tapped, so that the voltage from each winding end to the center tap is 24 VAC. The maximum voltage between the center tap and either end is 30 VAC. This produces an unloaded motor bus voltage of 42.5 volts.

#### DC Power

For low power applications the DC input should be applied between pins 1 (+) and 2 (-) of J1. For higher power applications, the input rectifier diode stress can be lowered by connecting pins 1 and 3 of J1 together so that both sides of the AC rectifier are used. The model 210 CAN NOT be powered by connecting the positive input to pin 3 only.

#### Overload Protection

There is no input over current protection in the Model 210. Suitable fusing must be provided by the user's power input circuit.

### Motor

The Model 210 is designed to power a standard 120°, three phase brushless DC (BLDC) motor with three wye connected windings tied to a common ground, and three open collector hall effect commutation sensors. The motor windings and the sensors are connected to the appropriate signals on the motor connector J5 as shown in the table below.

J5 is configured to plug directly onto the motor cable of a Hurst 482x series BLDC motor. For connection to other motors see the motor interfacing section below.

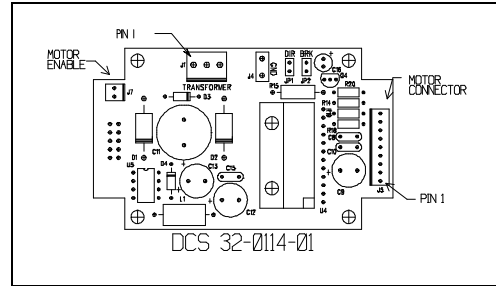

**Figure 1:** Back View of Model 210

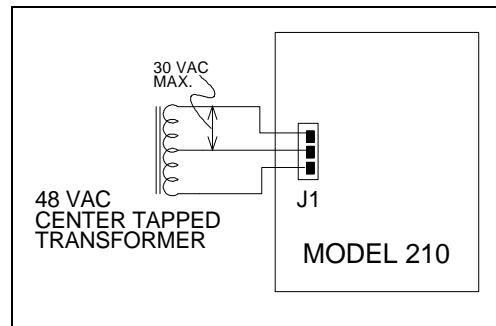

**Figure 2:** Typical Input Power Connection

## Model 210 interfacing guide

---

**Table 1:** Motor Connector Pinout

Pin #	Name	Function
1	PHC	Motor winding 'C'
2	PHA	Motor winding 'A'
3	PHB	Motor winding 'B'
4	MGND	Common end of motor windings
5	+5V	Power for hall effect sensors
6	SGND	Auxiliary ground
7	HE2	Hall effect sensor 1 input (pulled up to 6.8V)
8	HE3	Hall effect sensor 2 input (pulled up to 6.8V)
9	HE1	Hall effect sensor 3 input (pulled up to 6.8V)

### Jumpers

There are three jumpers on the Model 210. They are active when closed.

#### **Enable**

The motor will not run unless this jumper is closed. This jumper can be opened or closed at any motor speed setting.

#### **Brake**

Closing this jumper shorts all three windings to ground through the drive transistors, making it very difficult to turn the motor shaft while the controller is powered. **Closing this jumper when the motor is operating at high speed and/or with a large load can cause currents large enough to damage the controller.** It should only be closed when the motor is lightly loaded and moving slowly. It should never be used to stop the motor under load.

#### **Direction**

Closing this jumper reverses the motors rotation direction. **Closing this jumper when the motor is operating at high speed and/or with a large load can cause currents large enough to damage the controller.** This jumper should be opened or closed only when the motor is stopped..

## Interfacing the Motor

The commutation sequence of the motor windings as a function of the hall effect sensor input values is shown in the table below. There are no universal standards for naming the motor signals. The only way to determine which motor leads are connected to which pins of J5 is to consult the winding polarity and sensor input relationships required by the motor and make the correct connections based on the table below.

Hall sensor inputs			Motor winding polarity		
HE1	HE2	HE3	PHA	PHB	PHC
High	Low	High	Open	Low	High
High	Low	Low	High	Low	Open
High	High	Low	High	Open	Low
Low	High	Low	Open	High	Low
Low	High	High	Low	High	Open
Low	Low	High	Low	Open	High