

model 301



**Microprocessor Based, Infra-red
Environmental CO₂ Concentration Sensor**

Operator's manual

(spline)

DIGITAL CONTROL SYSTEMS

7401 SW Capitol Hwy.

Portland, OR 97219 USA

503/246-8110 ♦ 503/246-6747 (fax)

© 2000

Date

3/22/00

Model 301 Operators Manual

Scope.....	1
Introduction.....	1
Specifications.....	2
Installation	3
Cover Removal.....	3
Mounting	4
Wiring.....	4
Power Supply.....	5
Transformer Rating.....	5
Sharing Power Transformers	6
Connecting Multiple Sensors to a Controller	6
Signal Output.....	7
Voltage	7
4 - 20 mA	8
Contact Closure	8
Verifying Voltage Or Current Output Connection.....	10
Altitude Correction.....	10
Altitude Correction Procedure	11
Cover Replacement	12
Operation	12
Status Indicator.....	12
High CO2 Limit.....	12
Adjusting Setpoint.....	12
Setting High Limit Contact Polarity.....	13
Calibration	13
Verification Procedure	13
Duct Sampling Option	16
Overview	16
Duct Kit Contents.....	16
Duct Kit Installation	17
Limited Warranty and Remedies.	18

Model 301 Operators Manual

Scope

This manual pertains to DCS Model 300s with firmware version SPL_008 and above.

Introduction

The Model 301 is a non-dispersive infra-red analyzer designed for measuring environmental CO₂ concentration in indoor living spaces. Its measurement range of 0 - 2000 ppm (part per million; 1000 ppm = 0.1%) covers the range required to monitor compliance with ASHRAE or other ventilation efficiency standards.

The Model 301 provides numerous output options. An optional LED readout is available to display the concentration at the unit. A Voltage or 4 - 20 mA current output to transmit CO₂ levels to control systems is standard. An optional relay can be set to close (or open) when the concentration rises above a user adjustable setpoint.

The line power capable contact closure can directly control the fresh air damper to maintain carbon dioxide levels below a preset limit in simple systems. More sophisticated installations can take advantage of the voltage or current loop outputs to closely control ventilation conditions.

Packaged in a rugged metal case, the Model 301 can take the abuse encountered in real world applications. Its clearly visible pilot light indicates power on and high limit status at a glance.

A simple one point calibration procedure that requires no special fittings or adapters makes the Model 301 quick and easy to maintain.

Model 301 Operators Manual

Specifications

Operating Principle	Non-dispersive infrared (NDIR)
Gas sampling method	Diffusion or pumped sample
Measurement Range	0 - 2000 ppm CO ₂ contact factory for other ranges
Maximum drift (per year)	±75 ppm
Accuracy	±5% of reading or ±75 ppm, whichever is greater
Repeatability	±20 ppm
Minimum Calibration Interval	One Year
Response time	Less than 1 minute
Operating temperature range	0 to 50 ° C
Storage temperature	-30 to + 70 ° C
Power requirements	10 - 35 VDC 8 - 28 V _{RMS} AC
Power consumption	less than 1.5 W
Calibration adjustments	Span only (offset electronically nulled)
Calibration verification procedure time	10 minutes typical
Dimensions	6" x 2" x 4"
Voltage output (linear)	0 - 1 VDC standard (other voltage ranges available)
Current output (linear)	4 - 20 mA
Warm up time	5 minutes
Weight	Less than 2 Lbs
Optional Digital Display	4 digit, .56" LED
Operating life expectancy	10 years typical
Warranty	Two year, parts and labor through repair or exchange

Model 301 Operators Manual

Installation

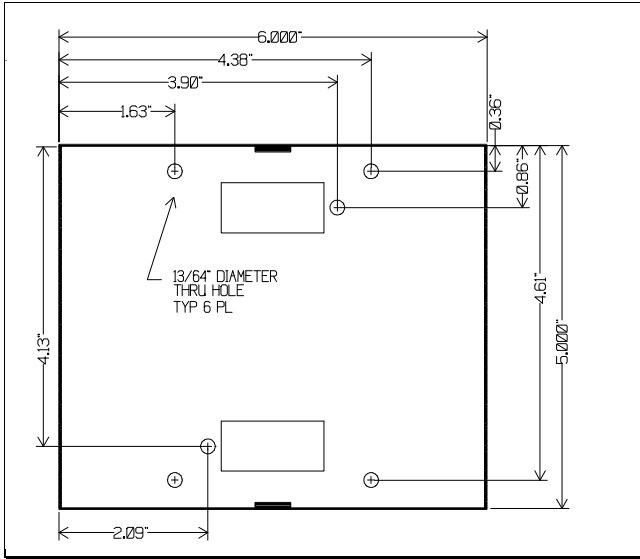

Model 301 Mounting Dimensions

Cover Removal

To remove the front cover of the Model 301 proceed as follows

1. Remove the two screws holding the cover to the base plate.
2. Pull the cover slowly away from the base plate.
3. Disconnect the status LED and the LED display cable (if display option is present) at the circuit board.
4. The locations of controls and terminals on the circuit board are shown in the part location figure on page 3.

Model 301 Operators Manual

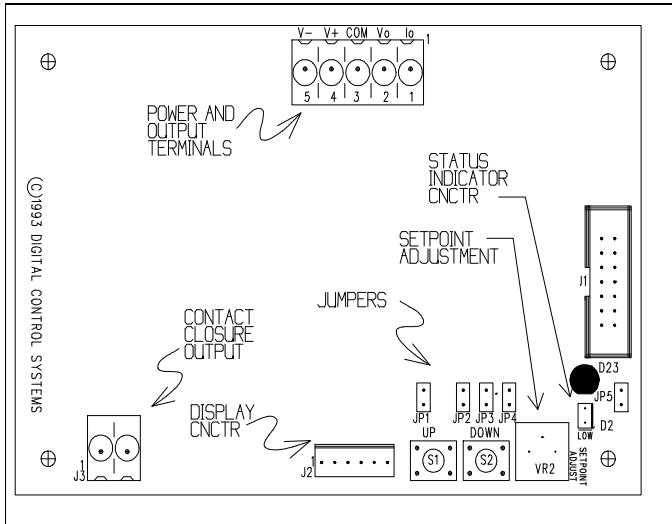

Model 301 Circuit Board Part Locations

Mounting

The Model 301 is designed for flush mounting to a flat surface with up to four fasteners. The locations of the four mounting points are shown in the mounting dimensions figure above. There is a rectangular wiring cutout in the base plate near the terminal strip.

Wiring

This section describes the external connections to the Model 301. Wiring enters the chassis through the cutout in the back panel under the main five position terminal block at the top center of the circuit board. All external connections are summarized in the table on page 9, and discussed in more detail in the sections that follow.

Model 301 Operators Manual

Power Supply

The Model 301 can be powered from either AC or DC supplies. When using a DC supply, be careful to observe the polarity. The DC input voltage must be between 10 and 20 volts DC.

When powered from an AC supply, the 'V-' terminal must be connected to the grounded leg of the power supply. AC input voltage must be between 20 and 30 volts RMS.

The Model 301 uses a switching power supply, so that the input power remains approximately constant over the input voltage range. The higher the input voltage, the lower the input current.

Transformer Rating

To determine the minimum transformer rating, multiply the number of model 301s to be connected to the transformer by 15 and add the VA requirement for the controller.

The output voltage of the transformer may never fall below 20 volts RMS.

Model 301 Operators Manual

Sharing Power Transformers

When using a common AC supply for multiple model 301s and/or the controller to which they are connected, the two legs of the power transformer secondary must be identified and kept separate. The transformer secondary leg connected to the grounded side of the controller's power terminal must be connected to the 'V-' terminal of all the model 300s. The secondary leg connected to the controller's ungrounded ("Hot") power terminal must be connected to the 'V+' terminal of all the model 300s.

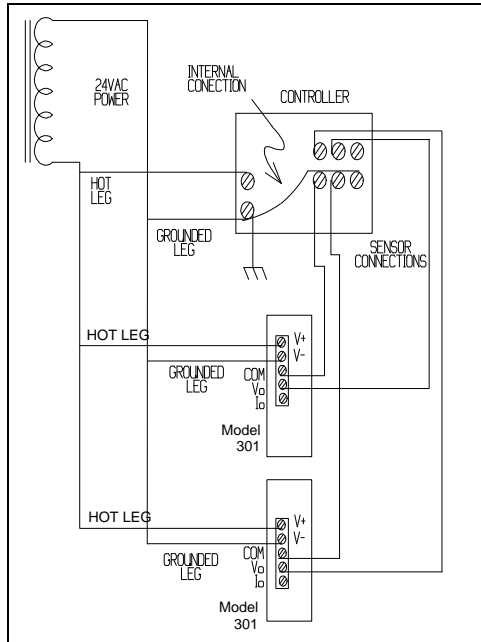

power terminal must be connected to the 'V+' terminal of all the model 300s.

Swapping the power connection at any of the model 301s forms a high power ground loop that will introduce huge errors into the sensor's output signal, and may damage both the model 301 and the controller.

Connecting Multiple Sensors To A Single Controller

When the power supply connections are made as described above, the voltage outputs of multiple model 301s can be connected to the same controller. The 'COM' terminals of all the model 300s may be connected together at the

Model 301 Operators Manual

common negative sensor input terminal of the controller. The 'Vo' terminal of each model 301 must be connected to the corresponding positive sensor input terminal of the controller.

The current outputs of multiple model 301s that are connected to a single transformer **CAN NOT** be connected to a single controller. If current outputs of multiple model 301s are connected to a single controller, **EACH MODEL 301 MUST HAVE ITS OWN TRANSFORMER.**

Signal Output

The Model 301 provides either a voltage or a 4 - 20 mA output. Only one or the other can be connected on a unit. The analog output signal is updated only while the concentration reading is stable. If a sudden change in concentration occurs, the output will not show any change until the detector stabilizes at the new value.

Voltage

The voltage output appears between the 'Vout' and 'COM' terminals of the five position terminal strip J5. 'Vout' is the positive terminal. The output voltage increases linearly from 0 volts at 0 ppm to full scale voltage at 2000 ppm. The standard output voltage range is 0 to 1 volt.

Model 301 Operators Manual

4 - 20 mA

The current flows out of the 'Iout' terminal and into the 'COM' terminal. The current ranges from 4 mA at 0 ppm to 20 mA at 2000 ppm. The maximum loop resistance with a 10 volt power supply is 500 Ohms, and increases as the power supply voltage is increased.

Contact Closure

This option provides a 2 amp, 24VAC contact that opens or closes when the measured CO₂ concentration rises above a preset limit. The two sides of the contact are available at the two position terminal strip marked J3 on the circuit board (see the parts location drawing on page 3).

The optional contact closure is adjustable across the full range of the unit.

Model 301 Operators Manual

Cnctr Number	Contact Designator	Signal Description	Comments
J1	none	The detector assembly ribbon cable is connected here.	Detector assembly should not be connected while the control board is under power.
J2	DISPLAY	The optional digital LED display is connected here.	
J3	none	When jumper JP5 is closed, the two terminals of J3 are closed when the CO ₂ concentration is above the setpoint. When jumper JP5 is open, the two terminals of J3 are open when the CO ₂ concentration is above the setpoint.	The maximum rating for this contact is 5A at 220 VAC.
J50	V-	Negative side of supply voltage.	See Power Connection section on page 6 when powering the unit from a shared AC supply.
	V+	Positive side of supply voltage	
	Iout	Source terminal for current loop analog output.	The current loop is connected between this terminal and "COM".
	Vout	Voltage proportional to CO ₂ concentration is present at this terminal.	
	COM	Reference potential for output signal voltage, and return for current signal.	When the voltage output is used, the receiving circuit should use this pin rather than "V-" as the reference potential.

Model 301 Connector Summary

Model 301 Operators Manual

Verifying Voltage Or Current Output Connection

After the voltage or current output of the Model 301 is connected to a controller or indicator, the following check should be performed to ensure that the connection has been properly established and is transmitting the correct values.

1. Borrow the shorting block normally used to set the relay contact polarity at jumper JP5 to connect the two pins of jumper JP4 (see part location figure on page 3).
2. The Model 301 sets its output to a value corresponding to its full scale ppm reading. The receiving device should be responding accordingly.

If the receiving device shows no change when JP4 is closed, verify that the wiring is correct.

3. Remove the shorting block from JP4 and store it by placing it over only a single pin of any unused jumper. The Model 301 output now corresponds to the actual detected CO₂ concentration.

Altitude Correction

The Model 301 is factory calibrated for operation at sea level. When operated at higher elevations, the calibration must be adjusted by the amount shown in the altitude correction table below.

Model 301 Operators Manual

Altitude Correction Procedure

To adjust the calibration of a unit currently calibrated for sea level operation to a new altitude proceed as follows.

1. Let the Model 301 stabilize to the ambient CO₂ concentration, and record the reading in ppm.
2. Multiply the reading by the scale factor corresponding to the operating altitude in the altitude correction table.

For instance if the unit is operating at an altitude of 4000 ft, the scale factor from the table is 1.14. If the concentration reads 420 ppm, multiply 420 times 1.14 giving 478 ppm. Round to the nearest 10 ppm and adjust the display to read 480.

3. Borrow the shorting block normally used to set the relay contact polarity at jumper JP5 to connect the two pins of jumper JP2 (see part location figure on page 3) and use the 'UP' and 'DOWN' buttons to change the concentration to the value just calculated.
4. Remove the shorting block from jumper JP2 and return it to its previous position at jumper JP5.

ALTITUDE CORRECTION TABLE	
Altitude [feet]	Multiplication Factor
0	1.0
500	1.02
1000	1.03
1500	1.05
2000	1.07
2500	1.08
3000	1.10
3500	1.12
4000	1.14
4500	1.16
5000	1.18

Model 301 Operators Manual

Cover Replacement

1. Connect the two position status indicator connector and, if present, the five position display connector to their respective headers on the circuit board. See the part location figure on page 3.
2. Carefully slide the cover over the side flanges of the base plate and secure in place with the two cover retaining screws.

Operation

Status Indicator

An LED on the front panel of the Model 301 lights when the unit has power. If the high limit option is installed, the LED blinks when the detected concentration is above the current setpoint. If the setpoint option is not installed, the LED blinks whenever the concentration is above 1000 ppm.

High CO₂ Limit

The high CO₂ limit option provides a dry contact closure that activates when the detected concentration rises above the preset limit. The high limit setpoint can be varied over the full measurement range. The polarity of the contact (i.e. normally open or normally closed) is controlled by the setting of jumper JP5

Adjusting Setpoint

The optional contact closure is adjustable across the full range of the unit. The adjustment of set point is made by closing jumper JP3 and using the buttons to select the desired set point. If the optional display is installed, the setpoint value is displayed while jumper JP3 is closed. If the

Model 301 Operators Manual

display is not present the voltage or current output will indicate the set point while jumper JP3 is closed.

The status indicator on the front of the unit blinks when the concentration is above the setpoint.

The setpoint hysteresis is approximately 50 ppm.

Setting High Limit Contact Polarity

The polarity of the high limit contact is set with jumper JP5.

Jumper 5 ON	Contact closed above set point
Jumper 5 OFF	Contact open above set point

The Model 301 ships from the factory with a shorting block closing jumper JP5. For normally closed operation, remove the shorting block from both pins of JP5 and store it by placing it over only a single pin of JP5. The shorting block should not be removed, since it is required during the calibration procedure.

Calibration

This section describes the calibration verification procedure and calibration adjustment procedures.

Verification Procedure

A quick but approximate calibration verification can be done by placing the unit outdoors and letting the reading stabilize. CO₂ concentrations are typically between 350 and 450 ppm.

A more accurate calibration check requires the use of calibration gas of known concentration. To verify the Model 301's calibration proceed as follows:

1. Remove the front cover of the unit (see procedure on page 3).

Model 301 Operators Manual

2. Slide the foam filter sleeve away from the plastic cap at the top of the sensor assembly to expose one of the upper sample ports. Thread the supplied 10-32 threaded hose nipple (stored in the sensor mounting bracket) into the exposed sample port.
3. Using the supplied header, close the two pins of jumper JP2.
4. If the display option is not present, connect a volt or current meter to the analog output (either voltage or current) being used to transmit the sensor's readings.

If the display is present, calibrate its reading, not the analog output.

If no display is present, attach the leads to the appropriate terminals of the output terminal strip so that they are self supporting. Do not attempt to hold the probes against the terminals by hand during the calibration process.

5. Attach a flexible tube to the nipple and establish a flow of between 50 and 100 cc/min of calibration gas through the sensor.

Allow about a minute for the reading to stabilize. Be careful to avoid transmitting any mechanical vibration to the sensor through the tubing.

6. If the reading differs by more than ± 75 ppm from the known concentration of the calibration gas, use the 'UP' and 'DOWN' buttons (see parts location drawing on page 3) to adjust the reading.

Because of internal averaging the response to the 'UP' and 'DOWN' buttons is not immediate. Allow several seconds for the display to catch up after making an adjustment

Model 301 Operators Manual

7. When the reading agrees with the concentration of the calibration gas, remove the shorting block on jumper JP2 and store it by placing over only 1 pin of any unused jumper.
8. Turn off the calibration gas flow, remove the tube nipple from the sensor assembly and slide the filter sleeve over the sample port. Remove the meter leads from the terminal strip and replace the front cover (see procedure on page 3)

Model 301 Operators Manual

Duct Sampling Option

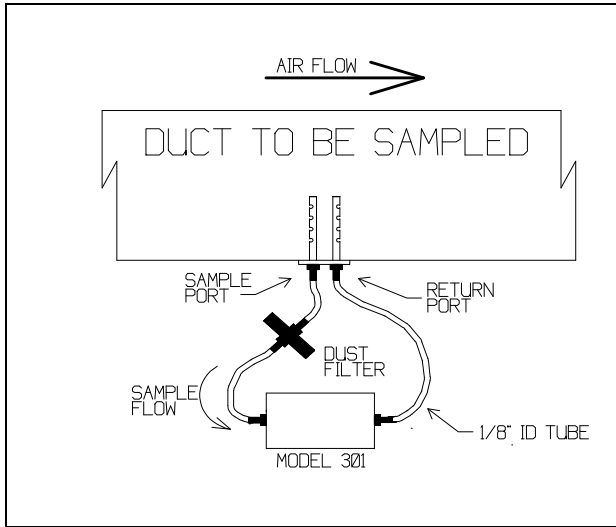

Figure 1: *Duct Sampling Schematic*

Overview

The duct sampling option is used to divert a portion of the duct airflow through the Model 301. The difference between the total pressure at the upstream sample port and the static pressure at the downstream return port propels the sample stream. Minimum recommended flow rate is 200 feet per minute.

Duct Kit Contents

- | | |
|-----------------------|-----------------------------|
| 1 dust filter | 2 sheet metal screws |
| 1 duct probe assembly | 2 lengths of 1/8" ID tubing |

Model 301 Operators Manual

Duct Kit Installation

- 1) Select a point along the duct where the probe assembly can be installed into unrestricted airflow without interfering with any internal duct components such as dampers, radiators, etc.
- 2) Mark and drill the four holes for the duct probe as shown in Figure 2. The centerline must be parallel to the air flow through the duct.
- 3) Install the duct probe assembly through the holes just drilled. **The sample port must be on the upstream side.** Secure the probe assembly in place with the two sheet metal screws.
- 4) Connect the open ends of the two tubes from the probe assembly to the two sample ports on the base of the Model 301. It makes no difference which tube is connected to which port on the Model 301.

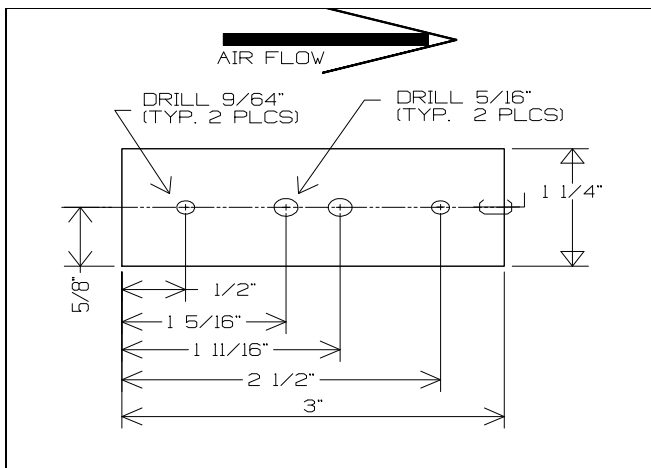

Figure 2: *Duct Probe Installation Dimensions*

Model 301 Operators Manual

Limited Warranty and Remedies.

DCS warrants to Buyer of the AirSense Model 300 that for two years from the date of shipment of Products to the Buyer that Products will substantially conform with the product specifications agreed to by DCS. This warranty is not transferable.

This warranty does not cover:

- Defects due to misuse, abuse, or improper or inadequate care, service or repair of Products;
- Defects due to modification of Products, or due to alteration or repair by anyone other than DCS; or
- Problems that arise from lack of compatibility between DCS' Products and other components used with those Products or the design of the product into which Products are incorporated. Buyer is solely responsible for determining whether Products are appropriate for Buyer's purpose, and for ensuring that any product into which Products are incorporated, other components used with DCS' Products, and the purposes for which DCS' Products are used are appropriate and compatible with those Products.

THE WARRANTY IN THIS SECTION IS IN LIEU OF ALL OTHER WARRANTIES, EXPRESS OR IMPLIED. DCS EXPRESSLY DISCLAIMS ALL IMPLIED WARRANTIES, INCLUDING THE WARRANTIES OF MERCHANTABILITY AND FITNESS FOR A PARTICULAR PURPOSE. DCS IS NOT RESPONSIBLE IN ANY WAY FOR DAMAGE TO A PRODUCT, PROPERTY DAMAGE OR PHYSICAL INJURY RESULTING IN WHOLE OR IN PART FROM (1) IMPROPER OR CARELESS USE, (2) UNAUTHORIZED MODIFICATIONS, OR (3) OTHER CAUSES BEYOND DCS' CONTROL. IN NO EVENT IS DCS LIABLE TO

Model 301 Operators Manual

THE BUYER OR ANY OTHER PERSON FOR COST OF PROCUREMENT OF SUBSTITUTE GOODS, LOSS OF PROFITS, OR FOR ANY OTHER SPECIAL, INCIDENTAL OR CONSEQUENTIAL DAMAGES.

To obtain service under this warranty, unless DCS agrees otherwise, Buyer must obtain a returned material authorization (RMA) number from the factory, pack any nonconforming Product carefully, and ship it, postpaid or freight prepaid, to the address provided when the RMA number is issued. Buyer must include a brief description of the nonconformity. Any actions for breach of this warranty must be brought within six months of the expiration of this warranty.

If DCS determines that a returned Product does not conform to the warranty in this section, it will either repair or replace that Product, at DCS' discretion, and will ship the Product back to Buyer free of charge. At DCS' option, DCS may choose to refund to Buyer the purchase price for a nonconforming Product instead of repairing or replacing it.

Units returned for service under this warranty and determined on examination to be operating properly are subject to a service charge.

