

MODEL 305E OEM CO₂ CONCENTRATION SENSOR

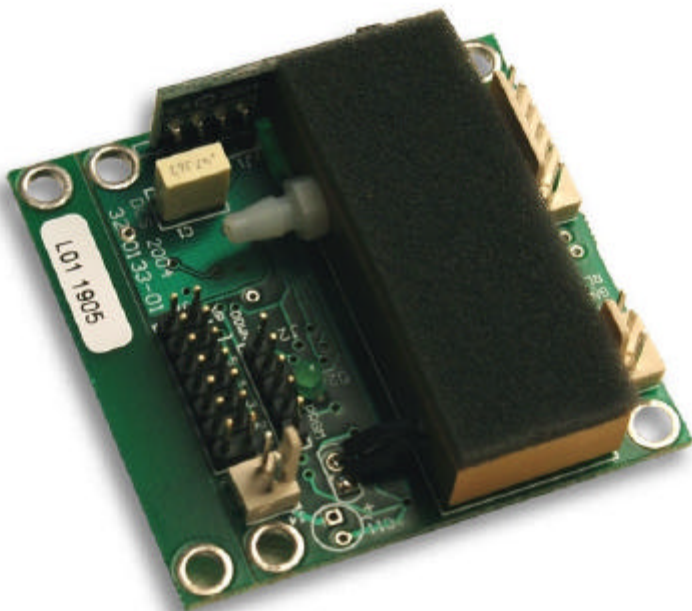

REFERENCE MANUAL

DIGITAL CONTROL SYSTEMS

7401 SW Capitol Hwy.
Portland, OR 97219 USA

503/246-8110 ♦ 503/246-6747 (fax)

www.dcs-inc.net

Revision History

Date	
11/11/2005	
3/16/2006	
1/21/2007	
3/8/2007	
3/16/2008	

DCS MODEL 305E USER'S MANUAL

Revision History	2
Scope.....	4
Introduction	4
Specifications	4
Mechanical.....	5
Electrical Connections.....	5
Operating Power	5
Analog Measurement Output.....	6
Digital Interface	6
Operator Interface.....	7
Using Jumper Functions.....	7
Measurement Calibration (JP2)	9
Elevation Correction	9
Relay Set Point.....	10
Relay Hysteresis	10
Analog Calibration.....	10
Analog Output Offset Adj. (JP4 & JP3).....	10
Analog Output Span Adj. (JP4 & JP5).....	10

Scope

This document applies to the -01 and higher circuit board revisions.. The part numbers 32-0133-01 or 32-0133-02 in the lower left hand corner of the circuit board identifies these units.

Introduction

The DCS Model 305e is very compact, cost effective, low power module for measuring ambient CO₂ levels. Designed for imbedded applications it operates from a single 5 volt DC supply and reports CO₂ concentration results as an analog voltage or digitally over an industry standard 3 wire serial bus.

A TTL level logic relay signal is also provided which is high when the CO₂ concentration is at or above the user adjustable relay setpoint.

Elevation calibration is also provided.

Specifications

Parameter	Value
Measurement Method	Non-dispersive infra-red (NDIR)
Measurement Range	0 - 2500 ppm CO ₂
Measurement Resolution	1 ppm
Measurement Accuracy	±5% of reading or ±100 ppm (whichever is greater)
Analog Output	0 - 2.5 VDC (nominally scaled at 1mV/ppm CO ₂)
Digital Interface	bi-directional SPI
Operating Power Requirements	4.75 to 5.25 VDC @ .05 Amps (average)
Operating Temperature Range	0 to 50° C.
Operating Humidity Range	0 to 95% RH (non-condensing)
Elevation Correction Range	0 to 5000 feet
Mechanical Size	2.1" x 2.2(1.9)" footprint, 0.75" tall
Relay Output	TTL level, 10 mA max.; adjustable hysteresis

Mechanical

The mechanical dimensions for the Model 305e are shown in Figure 1 to the right. The breakaway section on the right maintains the Model 305e mechanical spacing and mounting hole pattern is provided for legacy applications. This section can be snapped-off and discarded for a smaller footprint.

Note the clearance requirements shown in Figure 1. For tight fitting applications, the clearance above the board can be reduced to .46" by using parallel connectors. Contact the factory for details.

The four holes in the corners are intended for #4 mounting hardware.

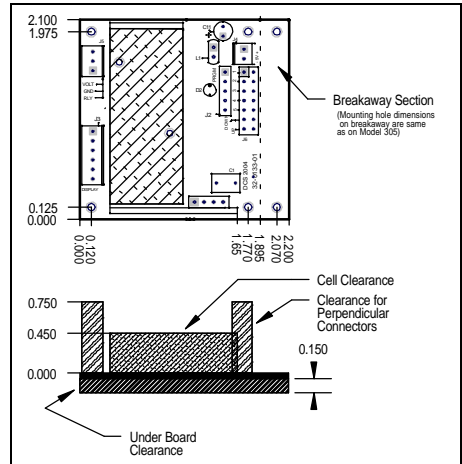

Figure 1: Model 305e Mechanical Dimensions.

Electrical Connections

Operating Power

The Model 305e's operating power is supplied through the two .025" square pin, .1" pitch harmonica connector located as shown in Figure 2.

		signals, and current return for 5 volt power.
6	Serial Data In	SPI input data to Model 305e

Table 1: Digital Interface Connector (J3) Pinout.

This interface can be used to deliver measurement results to a host system as well as controlling the Model 305e operations. Application specific configurations can be implemented to suit customer requirements. The SPI bus can operate in master mode for continuous updates or in slave mode where it must be queried by the application.

The standard firmware uses this port to communicate with an optional LED display module that normally shows the detected concentration in ppm.

Operator Interface

The operator interacts with the Model 305e using seven contact closure pairs as shown in Figure 2. The five pairs labeled '1' through '5' implement JP1 through JP5 respectively. The two contact pairs labeled 'UP' and 'DOWN' function like 'UP' and 'DOWN' buttons that are momentarily closed to simulate the action of push-button switches. A small (1/8" wide) blade screwdriver is a handy tool to use for momentary contact closure.

The operator interface is used to query and alter internal parameters. A jumper pair is typically closed with a shorting block to select the parameter to be accessed. The button pairs are then momentarily closed to alter the value.

Shorting blocks can be conveniently stored by placing them over only a single pin of a jumper.

Using Jumper Functions

Several of the five, 2 pin jumpers are used to view and adjust parameters as shown in Table 2 below. Placing a shorting block over the two pins corresponding to the jumper number closes that jumper. Functions are accessed by placing a shorting block on the jumper indicated in the table below. For some parameters a second jumper must be momentarily closed after the shorting block is placed on the first jumper.

DCS MODEL 305E USER'S MANUAL

If the optional display is connected, most functions will show a characteristic string in the display to identify the selected function. In the case of relay hysteresis, the current value is immediately displayed.

To change the value, momentarily close the 'UP' or 'DOWN' jumpers to increment or decrement the value.

When the desired value is being displayed remove the shorting block to restore normal operation. Some modes will reset the unit after the jumper is removed.

Jumper				
Shorting block	Momentary	Function	Display	Factory Default
JP2		Manual user calibration (at any gas concentration)	U.CAL	
JP3		Relay Setpoint	r.SET	1000 ppm
JP3	JP1	Relay hysteresis	reading	20 ppm
JP4	JP3	Analog Output Offset	L 0	
JP4	JP5	Analog Output Span	H I	
	DOWN (> 5 sec)	Elevation Correction	ELE	0 feet (sea level)

Table 2: Accessing User Alterable Parameters

Measurement Calibration (JP2)

When calibrating the model 305e make sure that the detector has stabilized at the concentration to which the measurement system will be calibrated before closing jumper JP2.

When jumper JP2 closed the display reads U.CAL and the measurement system verifies the reading for about 45-50 sec. to make sure that the gas concentration is stable. After about 50 seconds the display switches to read CO2 concentration in ppm (with decimal point following forth digit) and is ready for adjustment. With jumper (JP2) still closed, the UP & DOWN jumpers are used to adjust the displayed CO₂ concentration to the desired value.

Elevation Correction

Closing the DOWN jumper for 5 seconds (or longer) enters the elevation setting mode. If the display is connected it will show “ELE”. At this point the DOWN jumper is opened to make it available for altering the value.

Momentarily closing either the ‘UP’ or ‘DOWN’ jumpers causes the display to show the current elevation setting (in feet) and the analog output voltage sets to the corresponding value (1 mV = 4 feet).

Subsequent closures of the 'UP' or 'DOWN' jumpers increment or decrement the elevation value. After about 5 seconds of no jumper closures, the Model 305e exits this mode and returns to normal operation.

Relay Set Point

To view or alter the setpoint close JP3 to make display show 'r.SEL', then momentarily close either the 'UP' or 'DOWN' jumper to show the current relay setpoint in ppm CO₂. The 'UP' and 'DOWN' jumpers can now be used to adjust the displayed relay setpoint to the desired value.

Opening JP3 stores the new relay setpoint value and returns the unit to normal operation.

Relay Hysteresis

To view or alter the relay hysteresis close JP3 to make display show 'r.SEL', then momentarily close JP1 to show the current relay hysteresis. The 'UP' and 'DOWN' jumpers can now be used to adjust the displayed relay hysteresis to the desired value.

Analog Calibration

This calibration ONLY adjusts the scaling of the analog output voltage. It is not intended for primary calibration of the gas measurement system.

Calibrating the Analog output is a two part process. First close JP4 with a shorting block. This shows 'SEL' on the display. Then momentarily close a jumper to select offset or span calibration. JP3 allows adjustment of Low cal point (display reads Lo) JP5 is for calibration of the high cal point (display reads Hi).

Analog Output Offset Adj. (JP4 & JP3)

With JP4 closed, momentarily close JP3 to force the CO₂ measurement system to report 0 ppm. The UP & DOWN buttons are used to adjust the offset of the analog output to the desired value at 0 ppm. If the LED display is connected, it shows 'Lo' when jumper 3 is closed.

Analog Output Span Adj. (JP4 & JP5)

With JP4 closed, momentarily close JP5 to force the CO₂ measurement to report full scale concentration regardless of the actual gas concentration at the sensor. The UP & DOWN buttons are used to adjust the span of the analog output to the desired value at full scale.

DCS MODEL 305E USER'S MANUAL

If the LED display is connected, it shows 'Hi' when jumper 5 is closed.