



KCO-NO2 Sensor User's Manual

90-0201-01



KCO-NO2 User's Manual

Revision History

Revision	Date	Changes
90-0201-00	3/18/21	Original Issue
90-0201-01	4/12/21	Change CO sensor ToS to 200 ppm from 100 ppm.

KCO-NO2 User's Manual

Contents

Revision History	2
1 Specifications	4
2 Mechanical Installation	5
2.1 Enclosure Dimensions	5
3 Electrical Installation.....	6
3.1 Analog Reporting-Output Connections	6
3.2 Relay Connections.....	6
3.3 Power Connection.....	7
4 Operational Description	8
4.1 Normal operation.....	8
4.2 Startup.....	9
4.3 Setting Warning and Alarm Threshold.....	10
4.4 Warning and Alarm Conditions.....	10
4.5 Abnormal operation.....	10
5 Sensor Calibration	11
5.1 Calibration Gases.....	11
5.2 Calibration Procedure.....	13
6 Sensor Module Replacement.....	14
6.1 Sensor Errors	14
6.2 Replacement Sensors:.....	14
6.3 Field Replacement of Sensor Modules.....	14
7 Warranty.....	15
7.1 Duration	15
7.2 Limited Warranty and Remedies	15
8 Disclaimers.....	16
8.1 Inspection and Maintenance	16
8.2 Life Safety	16

KCO-NO2 User's Manual

1 Specifications

Mechanical	
Chassis Construction	Robust 18 Ga. Grey powder-coated steel. Hinged & Pad-lockable, or screw-on cover style available.
Weight	2.0 Lbs.
Operating Temperature	-20 to 50°C (-4 to 122°F)
Operating Humidity	15 – 90 %RH
Storage Temperature	0 to 20°C (32 to 68°F) to minimize sensor degradation.
Case Dimensions (H x W x D)	6.4" x 5.9" x 2.4" (163.5 x 150.8 x 60.7 mm)
Sensor Vents	Natural Ventilation through 18 0.1" diameter (2.54 mm) vents.
Recommended calibration cap diameter	20.5 mm (.807")
External Indicators	Separate tri-color LEDs indicates operational status of each sensor.
Knockouts	4 trade ½" knockouts (1 per side)

Electrical	
Operating Power Voltage	14 to 30 VAC (RMS) or 15 to 45 VDC polarity independent, isolated power supply
Power Consumption	< 5W
Control Relays	Two separate SPDT relays for warning and alarm outputs. UL rated: 10 Amps max at 277 VAC (RMS) or 30 VDC.
Concentration Reporting Outputs	Two powered 4–20 mA current loop outputs (one for each sensor). 4 mA output => 0 ppm, • 20 mA => full scale output. Maximum loop resistance: 510Ω
Termination	Pluggable screw-terminals for use with 12 AWG or thinner wire. Stranded wire recommend for 18 AWG or heavier wire.

Carbon Monoxide Sensor (CO)	
Sensor Type	Electrochemical
Measurement Range	0 – 200 ppm
Analog Output Range	4mA to 20mA (corresponds to 0 to 200 ppm)
Accuracy	±5% of Full Scale (typical)
Calibration Interval	6 Months; factory calibrated when new
Sensor Life	2 Year typical
Calibrated Field-Replaceable Sensor	KMOD-CO

Nitrogen Dioxide (NO₂)	
Sensor Type	Electrochemical
Measurement Range	0 –10 ppm
Maximum Permissible Exposure	150 ppm
Analog Output Range	4mA to 20mA (corresponds to 0 to 10ppm)
Accuracy	± 0.75 ppm (typical)
Calibration Interval	6 Months; factory calibrated when new
Sensor Life	2 Year typical
Calibrated Field-Replaceable Sensor	KMOD-NO2

KCO-NO2 User's Manual

2 Mechanical Installation

The Model KCO-NO2 is available in two versions of a gray, powder-coated, 18 Gauge steel enclosure. The removable, lockable, hinged-cover version is shown in Figure 2 and the screw-down cover version is shown in Figure 1. All electronics are attached to the front cover. There are 1/2" conduit knock-outs on all sides for electrical connections. In potentially damp locations the knock-out on the bottom of the case should be used to minimize the possibility of water entry.

DO NOT USE THE VENT HOLES FOR WIRE ENTRY.

- This unit is designed to mount to a rigid, vibration-free surface near the middle of the area to be monitored about 5 feet above the floor.
- It should be located where there is free airflow - avoid corners or recesses.
- The air vents on the sides of the enclosure should not be closer than 1 foot from the nearest perpendicular wall and must not be obstructed or painted-over.
- May be mounted in any orientation but hinge on the left side is most common.
- Mounting holes are made for direct wall screws for the surface encountered. (Mounting screws not provided) or switch box spacing.

2.1 Enclosure Dimensions

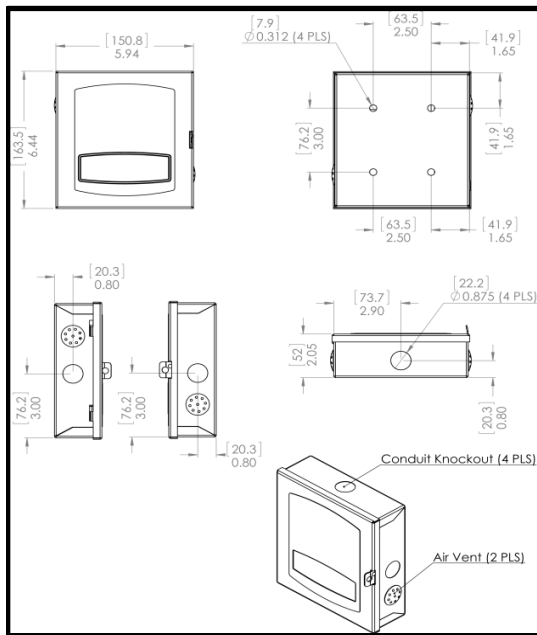

Figure 2: KCO-NO2 Hinged Front Panel Enclosure

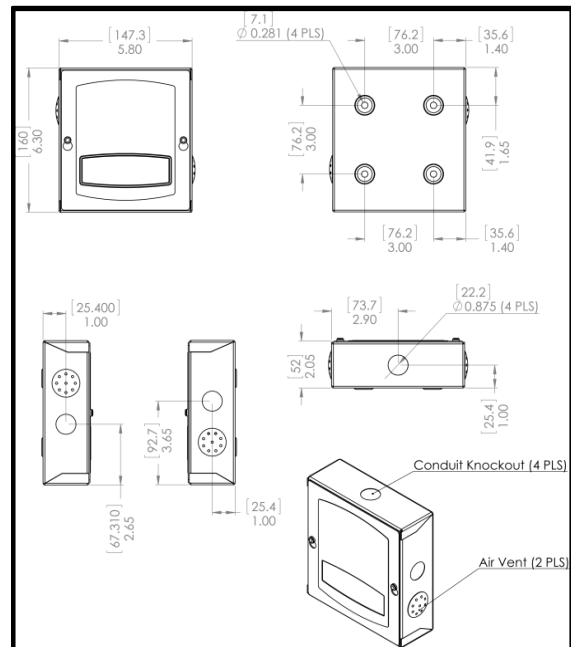

Figure 1: KCONO2 Screw Front Panel Enclosure

Case Style	Mtg hole diameter	Distance from center	
		Horizontal	Vertical
Hinged	5/16" (7.94 mm)	1.25" (31.75 mm)	1.50" (38.10 mm)
Screw-down	9/32" (7.14 mm)	1.50" (38.10 mm)	1.50" (38.10 mm)

TABLE 1: Mounting Hole Diameters & Locations

KCO-NO2 User's Manual

3 Electrical Installation

The controller is not equipped with a power switch; it is operational whenever sufficient power is applied to the low voltage power input terminals (do not connect to line).

All electrical connections to the controller are made through screw terminals that can be unplugged during wiring. The controller's enclosure contains multiple conduit knockouts for flexibility during installation; refer to Figure 2 and Figure 1 for details and dimensions of the enclosures.

3.1 Analog Reporting-Output Connections

Each sensor's readings are individually reported by the controller's two powered 4-20mA analog output connections. Current flows out of the '+' terminal and returns to the '-' terminal.

The **CO** output is provided at the terminals highlighted **green** in Figure 3 and the **NO₂** output is provided at the terminals highlighted **yellow** in Figure 3. The analog output connection has polarity as labeled on the controller silkscreen: care must be taken to ensure proper connection. To wire the analog output connections:

1. Power down the controller,. This can be done by unplugging the controller power terminal (See Figure 6).
2. Unplug the desired analog output screw terminal (either the NO₂ or CO terminal).
3. Connect the signal wires paying close attention to the polarity.
4. Plug the analog output screw terminal back into the controller.
5. Repeat this process for both analog outputs, then reconnect power.

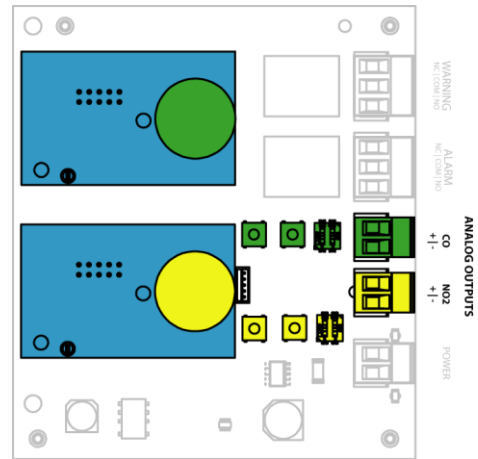

FIGURE 3: Location of Analog Output Terminals.

3.2 Relay Connections

The controller has two SPDT dry-contact relay output terminals (shown in Figure 4). The relays are UL rated at 10 Amps at up 277 VAC, and the associated circuitry meets UL criteria for connection to line voltage below 300 volts. Some jurisdictions may require such heavy gauge wires that the full capabilities of the relays are not operationally achievable.

The relay connections have three-terminal screw connectors that allow devices to be wired to the controller in either normally-open (*NO*) or normally-closed (*NC*) configuration. These outputs are activated when ambient air concentrations rise above the controller threshold settings (refer to *Section 4.3* for more information).

In the *NO Configuration*, the voltage attached to the *NO* terminal will be present at the *COM* terminal only when the relay output is activated.

In the *NC Configuration*, the voltage attached to the *NC* terminal will be present at the *COM* terminal while the relay output is deactivated: the voltage attached to the *NC* terminal is removed when the relay output is activated.

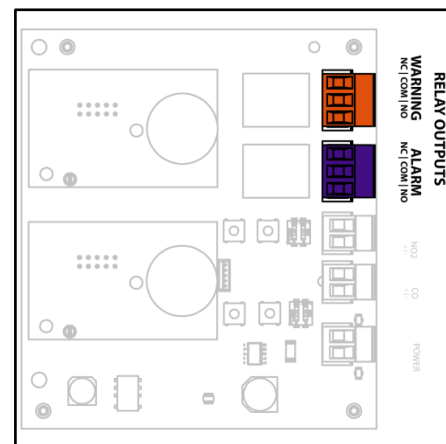

Figure 4: Relay Outputs

KCO-NO2 User's Manual

An example wiring diagram for relay connections is provided in Figure 5. When wired as shown, the fan will be energized in both warning and alarm conditions and the alarm will be energized only in the alarm condition.

To wire the *Warning* and *Alarm* relay outputs:

1. Determine if the device being attached to the relay output should be wired in NO or NC configuration.
2. Unplug the relay output screw terminal.
3. Connect the power source voltage for the device being attached to the controller's relay output to either the *NO* or *NC* location of the screw terminal (Figure 4).
4. Wire the power input of the device being attached to the controller's relay output to the *COM* location of screw terminal (Figure 4).
5. Plug the relay output screw terminal back into the correct location on controller board.

3.3 Power Connection

Power connection to the controller is made at the two-terminal screw connector located at the bottom-right side of the board (highlighted in Figure 6). Power to the controller can be either AC or DC voltage; DC voltage can be connected in either polarity.

The input power is electrically isolated from the analog outputs.

To wire power:

1. Open the controller's enclosure and unplug the screw terminal labeled **POWER** on the controller board.
2. Attach power wires to the screw terminal ensuring the connection is snug.
3. Plug the screw terminal back into the **POWER** receptacle on the controller board: this will cause the controller to power up and begin operation.

It is recommended that all wired connections are connected prior to providing power to the controller: see the following sections for details on making these connections.

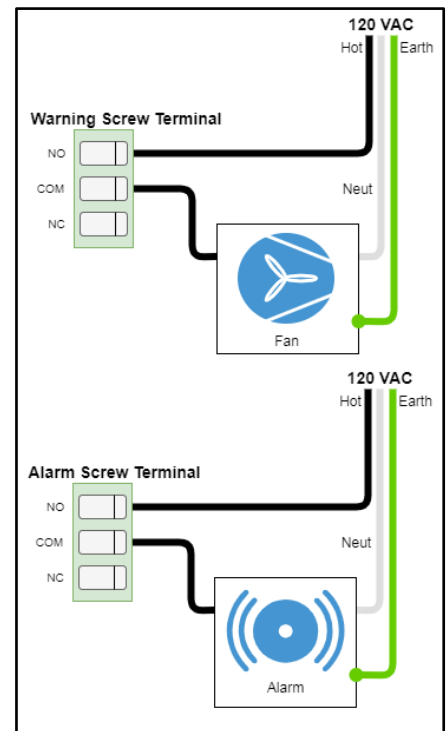

FIGURE 5: Example wiring Diagram for Normally Open Operation.

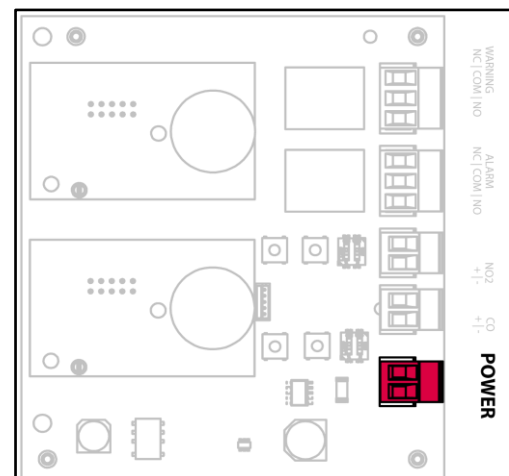

FIGURE 6: Location of Power Connector

KCO-NO2 User's Manual

Mode	Front Cover LED	Analog Output	Relays Actuated	Comment
Normal	Steady Green , Yellow or Red	4 – 20 mA	Depends on concentration	During normal operation
Standby	Various	4 mA	NONE	During start-up interval or any time during calibration
Sensor Error	Slow Blinking Red	20 mA	Warning/ Ventilation	After calibration of expired sensor or detection of sensor failure. Sensor is no longer operational and must be replaced.

TABLE 2: Operational State Summary

4 Operational Description

4.1 Normal operation

The KCO-NO2 is a ventilation and alarm controller that senses the presence of gasoline or diesel engine exhaust fumes and operates a Warning contact closure to trigger exhaust fans or a minor alarm annunciator when elevated levels of carbon monoxide (generated by gasoline engines and abbreviated CO) or nitrogen dioxide (from diesel engine exhaust and abbreviated NO₂) are detected. If the concentration of either gas exceeds its programmed alarm value, a second set of alarm contacts is operated to trigger an alarm.

The controller has two independent sensor modules; one for sensing carbon monoxide (CO), the other senses nitrogen dioxide (NO₂). The sensor modules are field replaceable: each sensor module can be replaced with minimal effort when it reaches end-of-life (EOL) while leaving the main control mounted and wired (refer to *Section 7.1*).

Status LED Color	Operational Status Description
GREEN	Concentration is below the ventilation threshold. No outputs are active.
YELLOW	Concentration is above the ventilation threshold and below the alarm threshold. Ventilation relay is active.
RED	Concentration is above the alarm threshold. Both ventilation and alarm relays are active.
BLINKING RED	Sensor module in need of service (refer to Section 6).

Table 3: Front panel status LED Indications.

Sensor	Concentration at 4 mA	Concentration at 20 mA
CO	0 ppm	200 ppm
NO ₂	0 ppm	10 ppm

Table 4: Sensor Analog Output Scaling

KCO-NO2 User's Manual

The controller has four factory-preset, pairs of warning and alarm levels for each gas (see Figure 8). Each setting determines both the sensor's warning and alarm thresholds (see *Section 4.2*).

When the concentration of **either CO or NO₂** rises above its configured warning threshold, the **WARNING** relay output is activated.

When **either CO or NO₂** concentration rises above its alarm threshold, the controller's **ALARM** relay is also activated (refer to *Section 4.2*).

When **both the CO and NO₂** concentrations are below the warning threshold, the **WARNING** relay is deactivated; the same action occurs for the **ALARM** relay.

The front cover has two LEDs indicators, one for the CO and the other for the NO₂ sensor module. These LEDs illuminate different colors to indicate normal (green), warning (yellow), alarm (red) and error (blinking red) conditions (see Table 3).

The concentrations of CO and NO₂ in the ambient air are reported at each sensor's analog output. The analog outputs range from 4 to 20mA during normal operation (see Table 4).

4.2 Startup

At startup, the controller has a short (less than 1 minute) warm-up period before it begins normal operation; during this time the controller will:

- Illuminate both the CO and NO₂ status LEDs green
- Output the minimum value of 4mA for both CO and NO₂. Analog outputs.
- Deactivate both the Alarm and Warning relay outputs.

KCO-NO2 User's Manual

4.3 Setting Warning and Alarm Threshold

The controller has a warning and alarm threshold for each gas. These threshold values can be adjusted for each sensor via dip switches on the controller's main board (shown in Figure 7) Refer to details on setting the thresholds for each sensor in Figure 8.

	NO ₂	CO
Federal OSHA Personal Exposure Limit (PEL).	5 ppm	50 ppm

TABLE 5: Federal OSHA exposure limits
(29 CFR 1910.1051 TABLE Z-1)

4.4 Warning and Alarm Conditions

The controller has two LEDs on the front panel (one for each sensor). These LEDs change color to indicate the controller's current operational status. Table 3 shows the behavior of the front panel LEDs during normal operation.

Two dry-contact SPDT relays are provided on the controller, these relays activate during warning and alarm conditions. Refer to *Section 3.3* for location and wiring information.

Readings for the two sensors are independently reported on the controller's two 4 – 20mA powered current loop outputs during normal operation. These outputs are electrically isolated from the operating power connection.

Table 2 lists the operational conditions that force the analog outputs to their limits regardless of ambient gas concentrations.

4.5 Abnormal operation

Both of these conditions will put the KCO-NO2 into 'Sensor Error' mode (see Table 2).

Sensor Expired

Happens only after a span calibration if the sensitivity of the sensor has decreased by more than the manufacturers specification (usually 20%)

Sensor Failure:

Can happen at any time. Caused when the sensor supervision circuitry detects a catastrophic loss of a sensor's sensitivity, usually caused by a depletion of the sensor's electrolyte through a leak or evaporation.

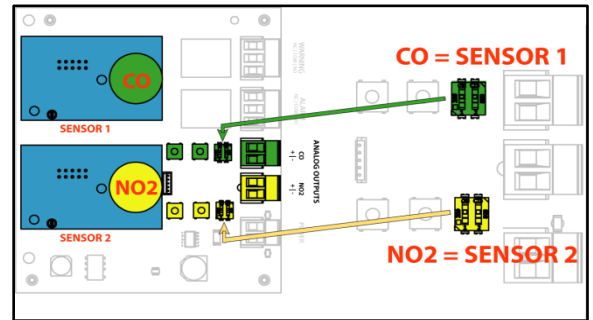

Figure 7: Dip Switch Locations. CO specific adjustments and connections are highlighted in yellow while NO₂ specific adjustments and connections are in green.

Dipswitch Setting	Threshold Set Points [ppm]			
	NO ₂		CO	
	Warn	Alarm	Warn	Alarm
	0.7	2.0	15	30
	1.0	3.0	25	40
	2.0	2.0	30	45
	2.5	4.5	35	45

FIGURE 8: Setting Warn & Alarm Set points

KCO-NO2 User's Manual

5 Sensor Calibration

The KCO-NO2 must be calibrated at least every six months to maintain the specified accuracy.

Calibration entails individually exposing each of the sensors to two gases of precisely known concentrations (See Table 6) so the measurement system can compensate for changes in the sensor's sensitivity.

The **UCK-3 kit** is available at Kele.com.

Both sensors first use the same zero gas cylinder for zero calibration, but then each sensor uses a different span gas cylinder for the span calibration.

A 'calibration cap' is required to cover the sensor body and form an isolated pocket at the sensor that is filled with the appropriate calibration gas supplied from cylinders of compressed gas through a regulator connected to it by typically ¼" OD gas tubing. Refer to the documentation for the calibration kit being used for instructions on how to assemble and operate its gas supply components.

Each sensor must be sequentially calibrated with two different gases. The Zero gas is the same for both sensors and is used for the 'zero' calibration, which must be done first. The 'span' gas is different for each sensor and used for the 'span' calibration which **MUST** be done **ONLY AFTER** a successful zero calibration. Each calibration is started with one of the two calibration buttons (ZERO and SPAN) for each sensor module as shown in Figure 9.

During calibration and for a period thereafter, the analog outputs are forced to 4 mA and the alarm relays are both deactivated to avoid spurious alarm conditions from residual span calibration gas that has not yet dissipated from the sensor.

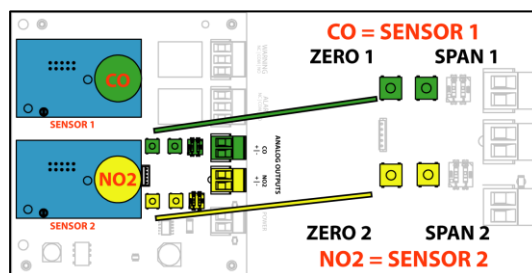

Figure 9: Location of Calibration Controls. CO is green; NO2 is yellow.

5.1 Calibration Gases

The table below shows the calibration gases required to calibrate the KCO-NO2.

Sensor	Calibration Gas	Mixture (by volume)	Kele Order Nomenclature
BOTH	Zero Gas	Air (18% to 21% O ₂ , balance N ₂) Often called "zero air" or "clean air"	GAS-02-18
CO	Span Gas	25 ppm CO, balance air	GAS-CO-25
NO ₂	Span Gas	10.0 ppm NO ₂ , balance air	GAS-NO2-10

TABLE 6: Gases required to calibrate KCO-NO2

A calibration kit [UCK-3](#) is available from Kele.com.

KCO-NO2 User's Manual

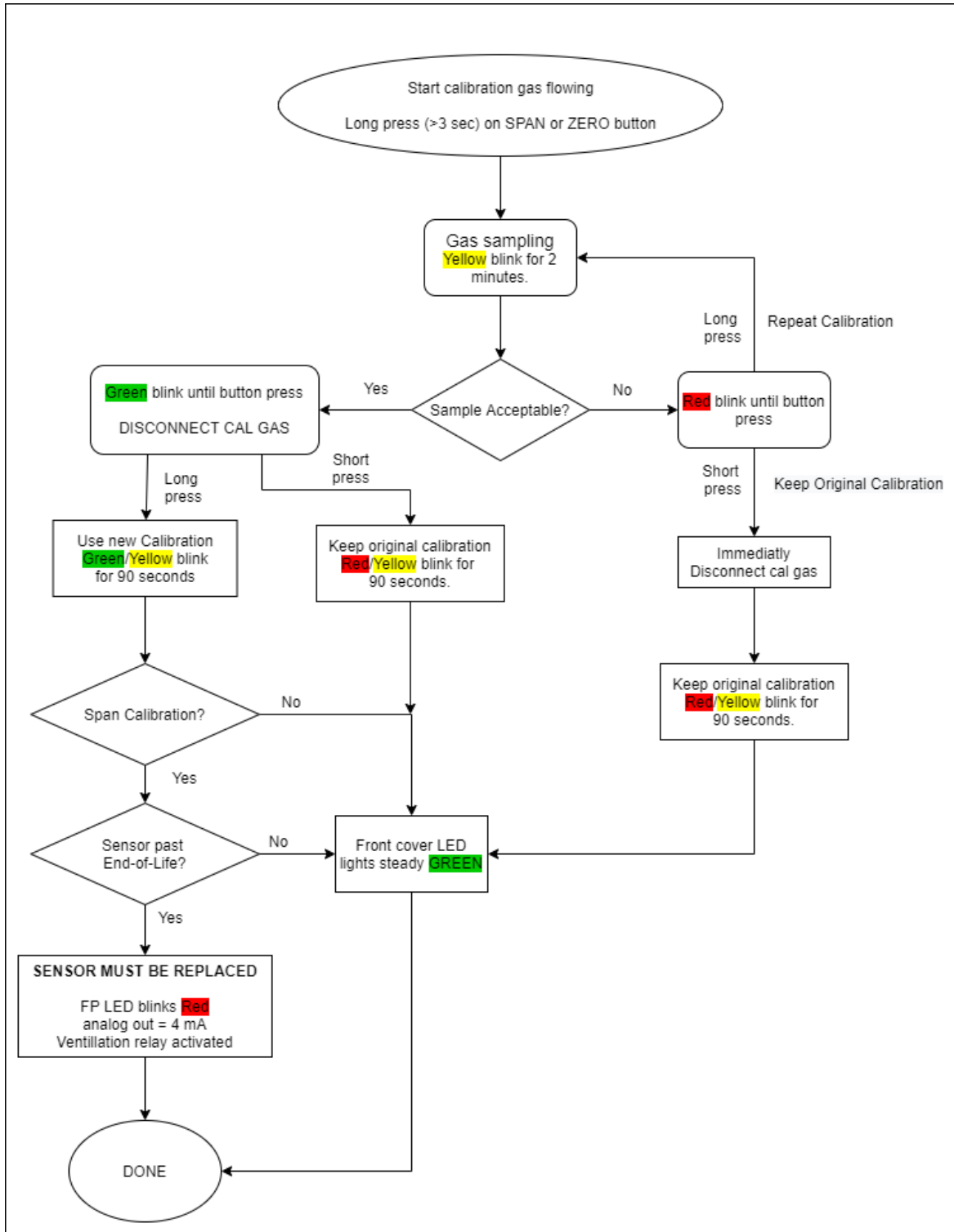

FIGURE 10: Calibration Flowchart

This procedure must be done twice (first as Zero then as Span) for each sensor

KCO-NO2 User's Manual

5.2 Calibration Procedure

The procedure below **MUST** be done twice for each sensor: first it is done as a zero calibration using the zero gas and only after a **SUCCESSFUL** zero calibration has been completed, the same procedure below is done again as a span calibration using the required span gas.

The progress and status of the calibration process is indicated by the color and flash-state of the front cover status LED of the sensor being calibrated.

For each calibration proceed as follows:

1. Flow the appropriate calibration gas to the sensor being calibrated using a calibration cap, following the instructions for the calibration kit being used.
2. Start the desired calibration by pressing either the 'ZERO' or 'SPAN' button of the sensor being calibrated (see Figure 9) for 3 seconds until the sensor's status LED starts blinking **YELLOW**. Gas sampling starts immediately.
3. Ensure that the calibration cap covers the sensor completely for the 2 minute sampling period. At the end of the sampling period, the sensor's status LED blinks **GREEN** if the gas sampling was successful or **RED** if not.

If successful (blinking GREEN): The sampling completed successfully.

Disconnect the gas and press the same button that started the calibration again for 3 seconds indicating the cal gas has been removed. The LED then blinks **GREEN/YELLOW** for 2 minutes indicating that the calibration was accepted.

If NOT successful (blinking RED):

The sampling can be re-started while the LED is blinking **RED** by pressing the same button that started the calibration again for three seconds until the LED again blinks **YELLOW**, then go to step 3 above.

OR

The sample can be discarded and the previous calibration restored by removing the calibration gas from the sensor then pressing and quickly releasing the same button that started the calibration. The LED switches to blinking **RED/YELLOW** for two minutes to indicate that the calibration was NOT applied.

In either case, the calibration is complete when the LED again returns to steady **GREEN**.

At the conclusion of a successful Span calibration the sensitivity of the sensor is compared to its sensitivity during initial factory calibration. If its sensitivity has fallen below manufacturer's end-of-life specification, the KCO-NO2 goes into Sensor Expired mode with the front cover LED slowly blinking **RED, the analog output at a constant 20 mA and the warning/ventilation relay activated. The sensor is no longer operational and must be replaced.**

KCO-NO2 User's Manual

6 Sensor Module Replacement

If there is an issue with the sensor module, the front panel LED will blink **red**. The 4-20 mA analog signal will output 20 mA to indicate sensor malfunction to the apparatus monitoring the output. When this occurs, the sensor module must be replaced.

6.1 Sensor Errors

The sensors are regularly tested to verify proper operation. If a sensor failure is detected:

1. its front panel LED will blink **red**.
2. the warning relay will be active.
3. the alarm contact will remain inactive.
4. the analog output will be forced to 20 mA to alert the device monitoring the analog reporting output that the sensor has failed.

When front panel status LED is blinking **red**, the sensor is no longer operational and must be replaced.

6.2 Replacement Sensors:

Calibrated sensor modules are available from Kele.

Carbon Monoxide (CO)	Nitrogen Dioxide (NO2)	Cal Kit
KMOD-CO	KMOD-NO2	<u>UCK-3 kit</u>

6.3 Field Replacement of Sensor Modules

Sensor modules must be replaced when they reach their End of Life.

To replace a sensor module:

1. Open the controller's front panel.
2. Unplug the controllers power connector (refer to Figure 6).
3. Unplug the failed sensor module by pulling the sensor module firmly away from the main board (Figure 11).
4. Plug the new sensor module into the vacant location: press the module firmly until the nylon standoff (highlighted in tan in Figure 11) at the bottom-left side of the board has been seated properly.
5. Plug in the controllers power connector.
6. Observe that the front panel indicator is no longer flashing red, and then close the controller's enclosure.

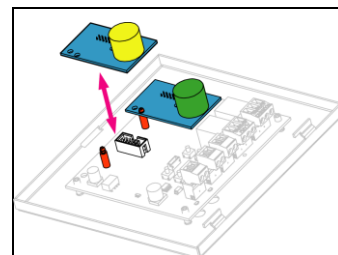

Figure 11: Sensor Module Replacement.

KCO-NO2 User's Manual

7 Warranty

7.1 Duration

Component / Class	Duration of Warranty
Enclosure & motherboard	7 years
Sensor modules	1 years

7.2 Limited Warranty and Remedies

Kele warrants to Buyer that for the duration stated in the “Duration” section above from the date of shipment of Products to the Buyer that Products will substantially conform to the product specifications agreed to by DCS. This warranty is not transferable.

This warranty does not cover:

- Defects due to misuse, abuse, or improper or inadequate care, service or repair of Products;
 - Defects due to modification of Products, or due to their alteration or repair by anyone not authorized by Kele.
 - Problems that arise from lack of compatibility between DCS's Products and other components used with those Products or the design of the product into which Products are incorporated.
- Buyer is solely responsible for determining whether Products are appropriate for Buyer's purpose**, and for ensuring that any product into which Products are incorporated, other components used with DCS' Products, and the purposes for which DCS' Products are used are appropriate and compatible with those Products.

If Kele determines that a returned Product does not conform to this warranty it will, at Kele's discretion, either repair or replace that Product, and will ship the Product back to Buyer free of charge. At Kele's option, Kele may choose to refund to Buyer the purchase price for a nonconforming Product instead of repairing or replacing it.

THIS WARRANTY IS IN LIEU OF ALL OTHER WARRANTIES, EXPRESS OR IMPLIED. Kele EXPRESSLY DISCLAIMS ALL IMPLIED WARRANTIES, INCLUDING THE WARRANTIES OF MERCHANTABILITY AND FITNESS FOR A PARTICULAR PURPOSE.

NEITHER Kele NOR ANY OF ITS SUPPLIERS IS RESPONSIBLE IN ANY WAY FOR DAMAGE TO A PRODUCT, PROPERTY DAMAGE OR PHYSICAL INJURY RESULTING IN WHOLE OR IN PART FROM (1) IMPROPER OR CARELESS USE, (2) UNAUTHORIZED MODIFICATIONS, OR (3) OTHER CAUSES BEYOND Kele OR ITS SUPPLIERS CONTROL.

IN NO EVENT ARE Kele OR ANY OF ITS SUPPLIERS LIABLE TO THE BUYER OR ANY OTHER PERSON FOR COST OF PROCUREMENT OF SUBSTITUTE GOODS, LOSS OF PROFITS, OR FOR ANY OTHER SPECIAL, INCIDENTAL OR CONSEQUENTIAL DAMAGES.

KCO-NO2 User's Manual

8 Disclaimers

8.1 Inspection and Maintenance

In order to maintain the specified accuracy this device, both its sensors must be calibrated at least every 6 months. During calibration the sensitivity of the sensor is compared to its sensitivity during initial factory calibration. If the sensitivity has fallen below the manufacturer's specification, the sensor has reached the end of its operating life and must be replaced. Contact Kele for a calibrated replacement module.

In harsh environments a sensor may fail prematurely. During normal operation the sensor is regularly tested to detect common failures. If a failure is detected, the front panel status LED for that sensor will blink red and its concentration-reporting analog output will stay at 20 mA until the sensor is replaced.

8.2 Life Safety

This unit is not designed, certified, sold or authorized for use in applications where the failure of this device could be reasonably expected to result in personal injury or death.



Scan for manual